

THE NEW JAGUAR
F-TYPE



>01

NEW DESIGN:

EVOLVES INTO A PURER, MORE SCULPTED AND ASSERTIVE EXPRESSION OF THE DEFINITIVE JAGUAR SPORTS CAR

>02

LUXURIOUS MATERIALS, EXACTING CRAFTSMANSHIP AND BEAUTIFUL DETAILING DEFINE THE **DRIVER-FOCUSED INTERIOR**

>03

SUPER-SLIM PIXEL LED HEADLIGHTS WITH 'CALLIGRAPHY' J SIGNATURE

DAYTIME RUNNING LIGHTS ACCENTUATE THE PURPOSEFUL, CONFIDENT STANCE

>04

F-TYPE R GAINS 575PS SUPERCHARGED V8 ENGINE

FOR 0-60MPH IN JUST 3.5 SECONDS, AND AN UPRATED CHASSIS WITH NEW SPRINGS, DAMPERS, ANTI-ROLL BARS, REAR KNUCKLES AND WIDER TYRES

>05

NEW 12.3-INCH HD VIRTUAL INSTRUMENT CLUSTER, ENHANCED MERIDIAN AUDIO AND SMARTPHONE PACK WITH APPLE CARPLAY **ENRICH THE DRIVING EXPERIENCE**





>06

**QUICKSHIFT
TRANSMISSION
METICULOUSLY
RECALIBRATED**

TO OFFER EVEN FASTER,
CRISPER GEAR CHANGES
USING LEARNING FROM
THE 200MPH JAGUAR XE
SV PROJECT 8

>07

**FIRST EDITION
WITH EXTERIOR
DESIGN PACK,**

BLACK CONTRAST ROOF,
UNIQUE 20-INCH WHEELS,
AND 12-WAY WINDSOR
LEATHER PERFORMANCE
SEATS WITH MONOGRAM
STITCH PATTERN



>08

**NEW 450PS
SUPERCHARGED V8
MODELS INTRODUCED
WITH REAR- AND
ALL-WHEEL DRIVE WITH
DYNAMICS TUNED FOR
EXPLOITABLE
PERFORMANCE
AND DRIVER
ENGAGEMENT**

AVAILABLE TO ORDER
NOW AT
AND PRICED FROM
£54,060
IN THE UK

The new Jaguar F-TYPE looks more beautiful than ever and embodies Jaguar design DNA in its purest form. The two-seat sports car offers a perfect balance of performance and driver reward with an even more muscular, assertive design and a cabin defined by rich, luxurious materials and beautiful details.

The range of powerful, responsive engines includes four-, six- and eight-cylinder options*, all matched to eight-speed Quickshift transmissions with full manual control using either the SportShift gear selector or the steering wheel-mounted paddles.

The new F-TYPE also offers more driver-focused technology, including a reconfigurable, high-definition, 12.3-inch TFT instrument cluster, Touch Pro infotainment system with Smartphone Pack** including Apple CarPlay as standard and software-over-the-air functionality so future infotainment updates can be made at the customer's convenience without having to visit a Retailer. Two superb Meridian sound systems also offer enhanced sound reproduction.

Julian Thomson, Design Director, Jaguar, said: "Design the most beautiful sports car, with purity, proportion and presence that's unmistakably Jaguar: that was the challenge we set ourselves. The new F-TYPE is more dramatic than ever, with even greater clarity of purpose in every line, surface and feature, and embodies true Jaguar design DNA."

State-of-the-art technologies together with luxurious materials and finishes deliver beauty with purpose in an interior which will delight driver and passenger alike even before the engine starts and the journey begins. Jaguar has been making sports cars for more than 70 years, and that rich heritage has inspired the team to create something truly extraordinary."



“

DESIGN THE MOST BEAUTIFUL SPORTS CAR, WITH PURITY, PROPORTION AND PRESENCE THAT'S UNMISTAKABLY JAGUAR: THAT WAS THE CHALLENGE WE SET OURSELVES. THE NEW F-TYPE IS MORE DRAMATIC THAN EVER AND EMBODIES TRUE JAGUAR DESIGN DNA.

”

JULIAN THOMSON
DESIGN DIRECTOR, JAGUAR

F-TYPE's award-winning design has evolved still further with a focus on even greater purity and discipline to the perfectly-sculpted form. Super-slim pixel LED headlights* with subtly updated signature 'Calligraphy' J daytime running lights, and sweeping direction indicators, blend perfectly into the 'liquid metal' surfacing of the new clamshell bonnet, exaggerating the car's visual width and accentuating its assertive stance. The new front bumper and subtly enlarged grille deliver even more visual impact and presence.

The rear haunches enhance the F-TYPE's inherently dramatic, purposeful form, while the new slender rear lights combine an unmistakable LED chicane signature, introduced by the Jaguar I-PACE all-electric Performance SUV, with subtle monogram pattern detailing and a fine 'pinstripe' beneath.

The interior combines traditional Jaguar craftsmanship with rich, contemporary materials such as Windsor Leather and satin-finish Noble Chrome. Beautiful details include monogram stitch patterns in the seats and door trims,

Jaguar Leaper motifs in the headrests, and subtle 'Jaguar Est.1935' markings on the centre console finisher, glovebox release button surround, and seatbelt guides.

The 12.3-inch reconfigurable HD TFT instrument cluster offers a choice of different displays, including full map mode but, as befits a true sports car, the default mode is characterised by the large central rev counter. This feature and the gearshift light subtly convey the F-TYPE's driver-focused character and performance potential.

Even before the drive begins, the F-TYPE delights the driver with the visual theatre of flush, deployable door handles and deployable air vents. Pressing the start button brings the car to life with its hallmark exhaust flare as purposeful as ever.

All engines – 300PS turbocharged four-cylinder, 380PS supercharged V6 and 450PS and 575PS supercharged V8s – feature active exhaust systems, which are switchable either as an option or as standard. Customers who choose the V8 models benefit from the new Quiet Start function,

which ensures a more subtle, refined sound – the electrically-actuated bypass valves in the rear silencer remain closed until they automatically open up under load. If desired, Quiet Start can be over-ridden by selecting Dynamic Mode or by pressing the switchable exhaust button before starting the engine.

The distinctive crackle and pop on the overrun synonymous with F-TYPE, remains, the sounds meticulously tuned to suit the range of powerful four-, six-, and eight-cylinder engines. Highly efficient, close-coupled particulate filters reduce emissions.

Alan Volkaerts, Vehicle Line Director, Jaguar F-TYPE, said: "The new F-TYPE is the definitive Jaguar sports car and continues to set the benchmark for design purity, driver engagement and reward, and a truly visceral driving experience – it makes every journey extraordinary.

"Its timeless looks are more assertive than ever, technologies such as the high-definition virtual instrument cluster deepen the driver-focused feel of the interior, while the range of powertrains offers a breadth of choice unrivalled in the segment. Enthusiasts will appreciate the new F-TYPE R's 575PS supercharged V8, enhanced chassis and intelligent all-wheel drive system, which deliver truly outstanding performance in all conditions while retaining its inherent tractability and usability."



The new F-TYPE's driver-focussed interior, like the exterior, has evolved into a purer expression of the car's elegance and performance. By concentrating on further refining the traditionally British Jaguar craftsmanship and adding discreet, beautiful details, the sense of luxury and sportiness has been heightened.

The 1+1 cockpit now features a 12.3-inch reconfigurable HD TFT instrument cluster, with graphics unique to F-TYPE. This offers a choice of display themes, including full map but, as befits a true sports car, the default mode is characterised by the large central rev-counter.

This feature and the gearshift light subtly convey the F-TYPE's character and performance potential, digitally enhancing the mechanical theatre of the pulsing red 'heartbeat' of the start button and the deployable air vents. The responsive, intuitive Touch Pro infotainment system's 10-inch touchscreen, matched to three tactile rotary controllers, offers the perfect balance of analogue and digital driver controls.

Lightweight slimline seats combine an ergonomically-optimised form with outstanding comfort, further enhanced by heating and cooling options. The seats come in two forms: Sport and Performance. The F-TYPE and F-TYPE R-Dynamic models come with the purest Sports version as standard. The Performance seat has more pronounced support at shoulder height, and is standard on the R and First Edition models.



Rich materials such as Windsor leather add a further touch of luxury, complemented by details such as the beautifully-crafted monogram stitch pattern - repeated in the door trim - and Jaguar Leaper and R motifs in the headrests. The seat belt guides are finished with discreet 'Jaguar Est. 1935 markings', which are proudly repeated on the glovebox release button surround. This subtle reference signifies the year the Jaguar name was first used by company founder Sir William Lyons to brand one of his beautiful cars.





Raising the output of the all-wheel drive F-TYPE R's supercharged V8 to 575PS and 700Nm (up from 550PS and 680Nm respectively) delivers truly outstanding performance in all weathers and in all conditions, while retaining its inherent tractability and day-to-day usability. Performance is exceptional: the benchmark sprint to 60mph takes just 3.5 seconds, while maximum speed is an electronically-limited 186mph.

The F-TYPE R's increased power is matched to a comprehensively uprated chassis with new, wider, 20-inch, 10-spoke wheels in Gloss Black with diamond-turned finish, and new adaptive dampers, springs, anti-roll bars and stiffer rear knuckles and ball joints, delivering even greater agility and responsiveness.

Taking all of the learning accrued from the development of the limited-edition, 200mph Jaguar XE SV Project 8, the Quickshift transmissions in both the new F-TYPE R and the 450PS V8 models have been meticulously recalibrated for a more engaging driving experience. The new F-TYPE R specifically offers even faster, crisper gear changes when the driver commands shifts manually via the steering wheel-mounted paddles or the SportShift gear selector. Both upshifts and downshifts are more immediate and give an even more connected and responsive feel.

The new 450PS supercharged V8 has been developed to offer exploitable and rewarding performance – its maximum torque of 580Nm being generated from just 2,500rpm. It is offered with a choice of all-wheel drive and – for purists – rear-wheel drive. Both versions can accelerate from 0-60mph in just 4.4 seconds, and reach a maximum speed of 177mph.

Customers also have the choice of the exclusive F-TYPE First Edition. Based on the R-Dynamic models, the First Edition is offered for one model year only, and has refinements such as the Exterior Design Pack in contemporary Dorchester Grey and five-spoke, 20-inch wheels in Gloss Technical Grey with contrast Diamond-Turned finish, complementing the choice of Santorini Black, Eiger Grey or Fuji White paint.

The interior features 12-way Windsor Leather seats in Ebony with Light Oyster stitching, or Mars with Flame Red stitching. Other highlights include the instrument cluster wrapped in Alcantara with Monogram embossing, aluminium gearshift paddles, an Engine Spin centre console finisher with First Edition branding, and an Ebony Suedecloth headliner.

F-TYPE TECHNICAL SPECIFICATION

ENGINE & TRANSMISSION	F-TYPE 300PS COUPÉ	F-TYPE 300PS CONVERTIBLE	F-TYPE 380PS RWD COUPÉ	F-TYPE 380PS RWD CONVERTIBLE	F-TYPE 380PS AWD COUPÉ	F-TYPE 380PS RWD CONVERTIBLE
Engine capacity (cc)	1,997		2,995			
Cylinders	Four in-line turbocharged		V6 Supercharged			
Valves per cylinder	4; DOHC		4; DOHC			
Bore / stroke (mm)	83.0 / 92.3		84.5 / 89.0			
Compression ratio	9.5:1		10.5:1			
Power PS (kW)	300 (221) @ 5,500rpm		380 (280) @ 6,250rpm			
Torque Nm (lb ft)	400 (295) @ 1,500-4,500rpm		460 (339) @ 4,500-5,000rpm			
Transmission	8-speed Quickshift					
CHASSIS						
Front suspension	Double wishbone					
Rear suspension	Double wishbone					
Front brakes	Single-piston sliding caliper; 355mm ventilated discs		Twin-piston sliding caliper; 380mm ventilated discs			
Rear brakes	Single-piston sliding caliper; 325mm ventilated discs					
Steering	Rack-and-pinion; electromechanical					
DIMENSIONS & WEIGHTS						
Length (mm)	4,470					
Width inc. / excl. mirrors (mm)	2,042 / 1,923					
Height coupé / convertible (mm)	1,311 / 1,307					
Wheelbase (mm)	2,622					
Track front / rear (mm)	1,596 / 1,647		1,584 / 1,628			
Weight; EU Unladen (kg)	1,595	1,615	1,647	1,667	1,726	1,746
Weight; DIN (kg)	1,520	1,540	1,572	1,592	1,651	1,671
Loadspace volume (litres)	299/509 with/without parcel tray		299/509 with/without parcel tray		299/509 with/without parcel tray	
Fuel tank (useable) litres	63		70			
PERFORMANCE & FUEL ECONOMY						
0-60mph (sec)	5.4		4.8		4.9	
0-100km/h (sec)	5.7		4.9		5.1	
Top speed mph (km/h)	155 (250)		171 (275)			
Fuel consumption mpg (litres/100km) NEDC equivalent combined	34.9 (8.1)		32.9 (8.6)		31.7 (8.9)	
CO ₂ emissions (g/km) NEDC equivalent combined	184		203		211	

Manufacturer's figures; correct at time of going to press

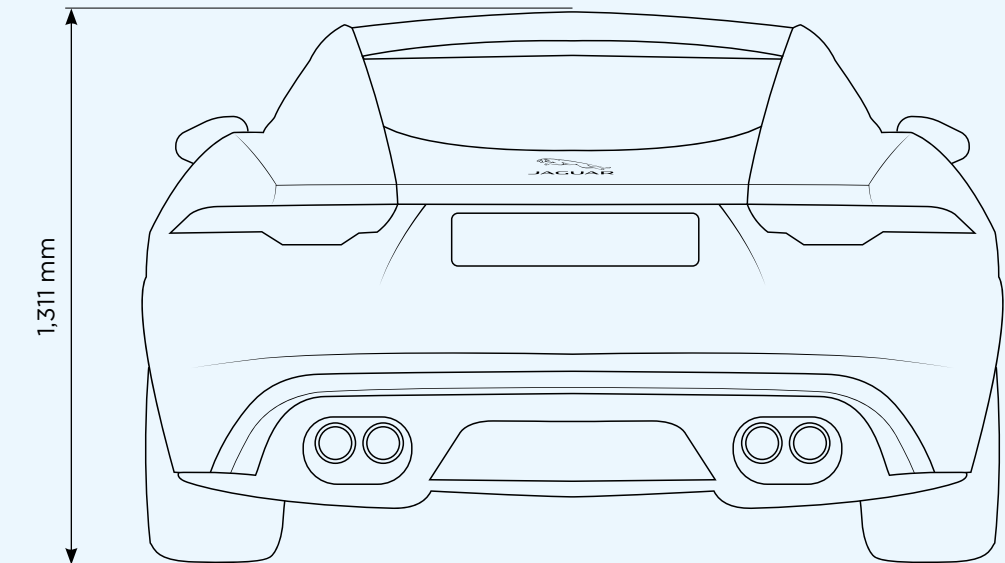
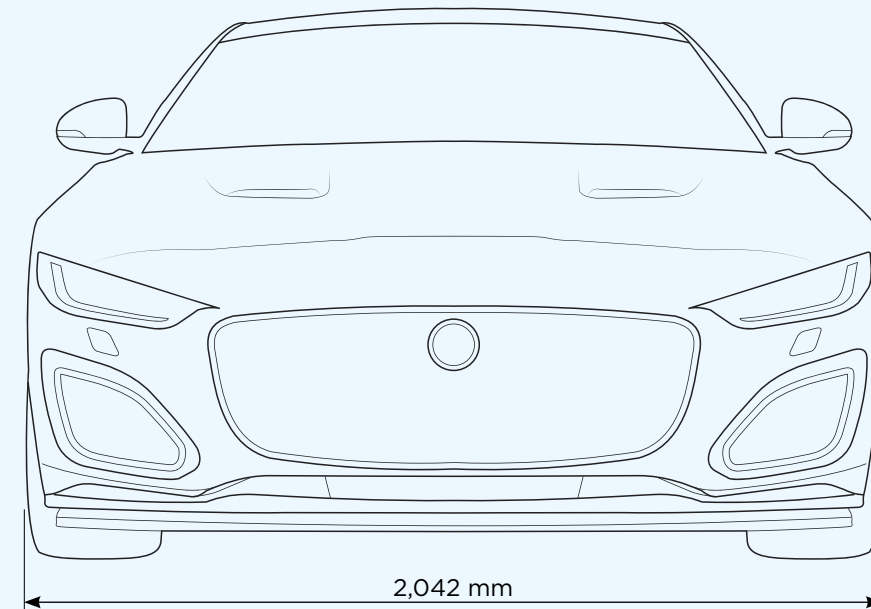
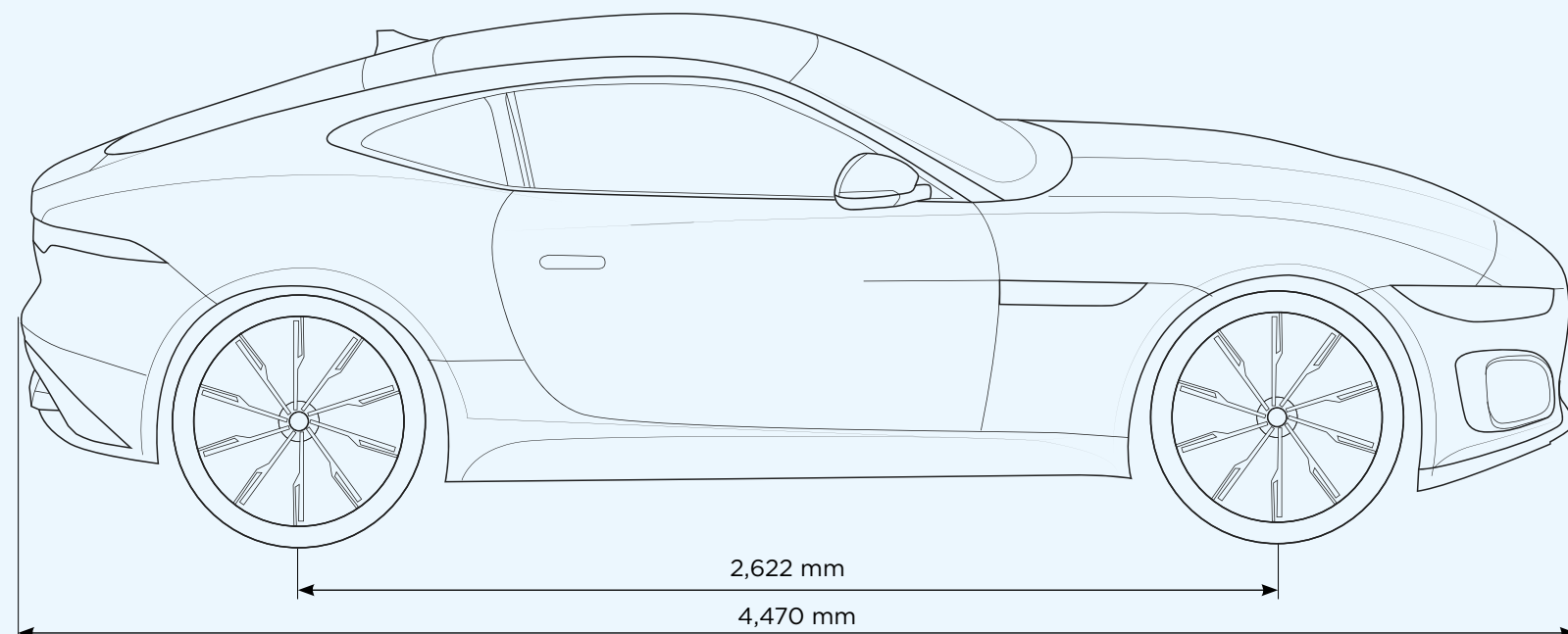

F-TYPE TECHNICAL SPECIFICATION

ENGINE & TRANSMISSION	F-TYPE 450PS RWD COUPÉ	F-TYPE 450PS RWD CONVERTIBLE	F-TYPE 450PS AWD COUPÉ	F-TYPE 450PS AWD CONVERTIBLE	F-TYPE 575PS AWD COUPÉ	F-TYPE 575PS AWD CONVERTIBLE
Engine capacity (cc)	5,000				5,000	
Cylinders	V8 Supercharged				V8 Supercharged	
Valves per cylinder	4; DOHC				4; DOHC	
Bore / stroke (mm)	92.5 / 93.0				92.5 / 93.0	
Compression ratio	9.5:1				9.5:1	
Power PS (kW)	450 (331) @ 6,000rpm				575 (423) @ 6,500rpm	
Torque Nm (lb ft)	580 (428) @ 2,500-5,000rpm				700 (516) @ 3,500-5,000rpm	
Transmission	8-speed Quickshift					
CHASSIS						
Front suspension	Double wishbone					
Rear suspension	Double wishbone					
Front brakes	Twin-piston sliding caliper; 380mm ventilated discs					
Rear brakes	Single-piston sliding caliper; 376mm ventilated discs					
Steering	Rack-and-pinion; electromechanical					
DIMENSIONS & WEIGHTS						
Length (mm)	4,470					
Width inc. / excl. mirrors (mm)	2,042 / 1,923					
Height coupé / convertible (mm)	1,311 / 1,307					
Wheelbase (mm)	2,622					
Track front / rear (mm)	1,584 / 1,628					
Weight; EU Unladen (kg)	1,735		1,818		1,838	1,838
Weight; DIN (kg)	1,660		1,743		1,763	1,763
Loadspace volume (litres)	299/509 with/without parcel tray	233	299/509 with/without parcel tray	233	299/509 with/without parcel tray	233
Fuel tank (useable) litres	70					
PERFORMANCE & FUEL ECONOMY						
0-60mph (sec)	4.4		4.4		3.5	3.5
0-100km/h (sec)	4.6		4.6		3.7	3.7
Top speed mph (km/h)	177 (285)		177 (285)		186 (300)	186 (300)
Fuel consumption mpg (litres/100km) NEDC equivalent combined	26.5 (10.6)		25.7 (11.0)		25.6 (11.0)	25.6 (11.0)
CO ₂ emissions (g/km) NEDC equivalent combined	244		252		252	252

Manufacturer's figures; correct at time of going to press

